

NORBIT iLiDAR LASER SENSOR

Turnkey Integrated Mobile LiDAR System For Complete Above Water 3D Point Cloud

The NORBIT iLiDAR is the most compact terrestrial mapping sensor fully integrated with a high resolution bathymetric multibeam system. With 300k data points per second in 30x360deg coverage it is an ideal tool for mapping above water surface terrain for a complete picture from a single pass. A robust single cable connects the IP67 iLiDAR sensor head to the topside Sonar Interface Unit (SIU) – with fewer connections, a rapid integration and compact size, surveys are easily carried out from any sized platform by personnel with minimal expertise.

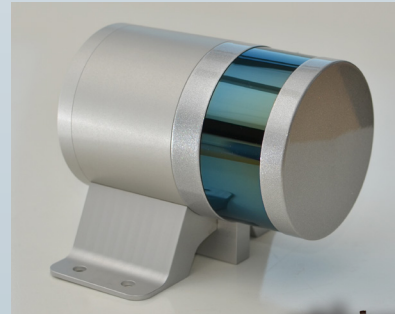

NORBIT's iLiDAR laser sensor is an all-new multi-sensing concept that combines multiple tightly integrated sensors into one hardware platform with a single LAN connection to survey laptop. Supported sensors include any combination of bathymetric multibeam echosounder, forward looking sonar, forward looking bottom detection and iLiDAR. Allowing you to...

Explore more with Norbit



Features

- ✓ Built For Marine Environment
- ✓ Hardware Time Synchronization
- ✓ Fully Integrated With iWBMS
- ✓ Robust Hardware Time Synchronization
- ✓ Single Cable Integration
- ✓ 360 Deg Field View
- ✓ Less Than 3 Kg

Applications

- ✓ Harbor Surveys
- ✓ River Surveys
- ✓ Height Clearance (Transmission Lines, Bridges, Etc.)
- ✓ Beach Nourishment Surveys
- ✓ Shoreline Charting Surveys
- ✓ Aquaculture
- ✓ Dredging
- ✓ Rock Dumping
- ✓ 360 Mapping

Options

- ✓ Senior Hydrographer for Support and Training
- ✓ Laptop
- ✓ Turnkey Survey Solutions
- ✓ Pole Mount And Travel Option
- ✓ Top-end INS (Roll, Pitch & Heading 0.01deg)
- ✓ Acquisition, Navigation & Post Processing Software
- ✓ Can be Delivered with all major software packages e.g. HYPACK, QINSy, EIVA, CARIS, etc.

NORBIT iLiDAR laser

Turnkey Mobile LiDAR System

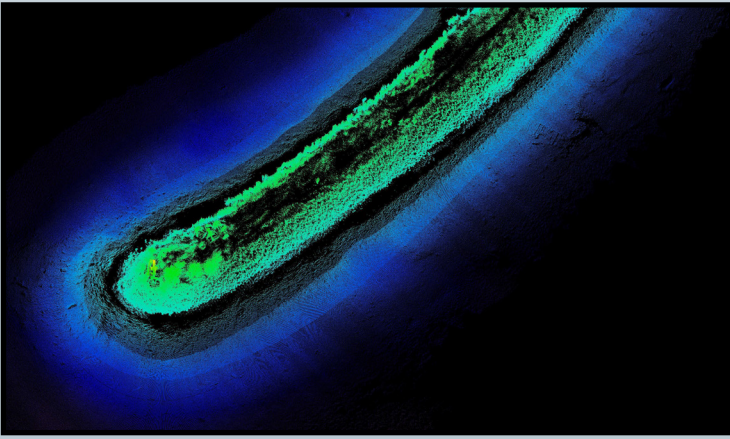
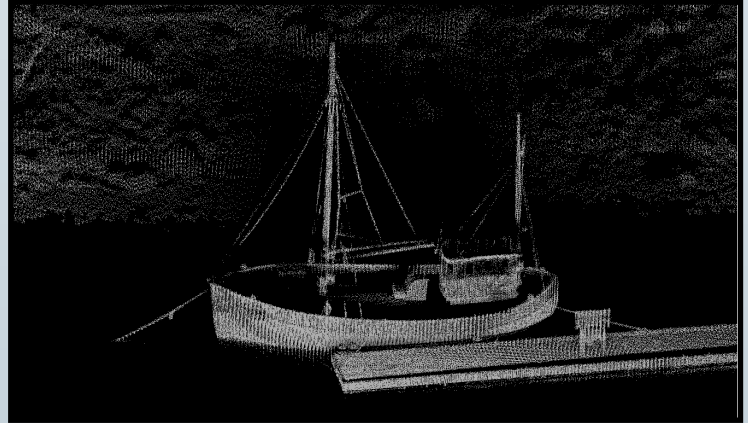
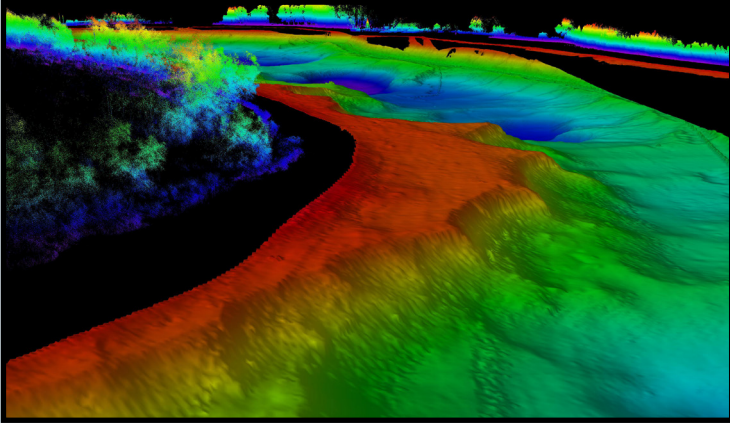

TECHNICAL SPECIFICATION

INFRARED LASER MODULE	1-20Hz-TIME OF FLIGHT MEASUREMENTS WITH DUAL RETURNS
FRAME RATE	5-20Hz (10Hz DEFAULT)
WAVE LENGTH PEAK	905nm (TYPICALLY) CLASS 1 EYE SAFE
OUTPUT	UP TO 300.000 POINTS PER SEC
ANGULAR RESOLUTION	2° BETWEEN EVERY OF THE 16 LASER/HORIZONTAL
ANGULAR RESOLUTION	0.1°-0.4° VERTICAL
FIELD OF VIEW	30° VER., 360° HOR
RANGE	100m
DATA I/O	NORBIT PROPRIETARY SYNCHRONIZED TIME STAMPED
POWER	8W (TYPICAL)
VOLTAGE	10-29VDC OR 110/220VAC (POWERED DIRECTLY BY THE SIU)
ACCURACY	2cm
DIMENSIONS (DIA. x H x L)	103mm x 130mm x 150mm
WEIGHT	2.4kg

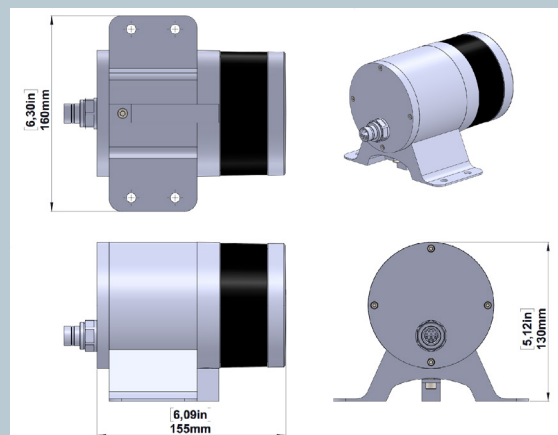

Part #24012



SERVO DRIVEN GEAR SYSTEM IN BOTH AXES WITH MANUAL CLUTCH OVERRIDE SYSTEM 3-AXIS FLUXGATE MAGNETOMETER + 3-AXIS ACCELEROMETER